

# TJ1400

## Ultra-Converged Broadband Access/Edge Platform

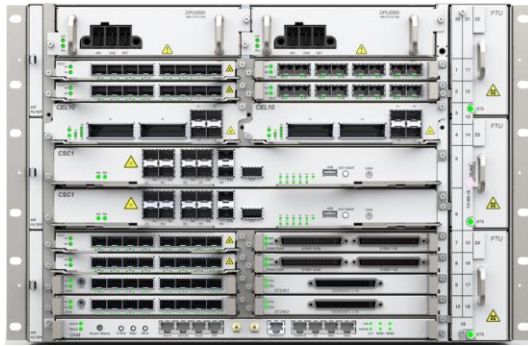

### DATA SHEET



### Product Highlights

**Convergence of TDM, PTN, OTN, LTE, GPON in a compact chassis**

**Integration of FTTx, WTTx, Active Ethernet**

**MEF 2.0 Compliant E-Line, E-Lan, E-Tree**

**Range of front-haul and back-haul solutions for 4G/LTE**

**High Capacity: Scalable from Megabits to Terabits**

**Technologies: Carrier Ethernet, MPLS, OTN, IP-VPN**

**Best-in-class Circuit Emulation: PDH, SONET/SDH**

### Key Features and Benefits

TJ1400 Ultra-Converged Broadband family of products is one of the industry's most feature-rich packet access and aggregation platforms. It provides unparalleled integration of Access, Transport and IP Network technologies in one integrated box and introduces a revolutionary way of building modern-day telecom infrastructure, bringing down the cost of network build-outs dramatically. TJ1400 Ultra-Converged Broadband platform is designed for cost-optimized delivery of Mobile Backhaul, Broadband Access and Enterprise Cloud Services migration infrastructure. It provides redundancy, low power consumption, and high service scale in a compact next-generation platform.

Key features include:

- Access technologies such as Active Ethernet (based on CE2.0), GPON, ERPSv2, Open ERPSv2
- Transport technologies such as PTN, MPLS-TP, Massive-scale Circuit Emulation with 1+1 APS support of TDM technologies such as PDH/SONET/SDH (E1/DS1/E3/DS3/STM-n/OC-n), Synchronization Services, OTN
- VR/VRF over MPLS-TP, Virtual Routers

**Software-defined Hardware™ and Modular Architecture:** Software-defined Hardware™ allows easy upgrades as per new protocols and technology standards. TJ1400 increases network reliability by providing optional redundant switch fabrics and the ability to support protected UNIs and NNIs across interface cards. Modular interfaces decrease meantime to repair by requiring only the affected module to be replaced, not the entire unit.

**Dense Circuit Emulation for Network Modernization:** TJ1400 supports dense circuit emulation and allows easy transition from circuit switched to packet Switched networks without changing service end-points.

**MPLS and IP-VPN:** TJ1400 supports MPLS label based connection oriented Ethernet which allows networks to easily scale from a few subscribers to millions of subscribers and a few services to thousands of services. The cost benefits of stat-muxing are combined with traffic engineering to lower CAPEX. OPEX reductions come through faster provisioning, robust protection and quicker outage analysis.

# TJ1400 Ultra-Converged Broadband Access/Edge Platform

**Advanced Ethernet Features:** TJ1400 provides best in class packet switching to create networks with the highest performance. Ingress rate limiting ensures that every packet entering the network is within the SLA bounds preventing any one customer/service from congesting/choking the network. Each packet is classified so that the appropriate network policies (like prioritization and scheduling) can be applied. Eight CoS queues, HQoS and scheduling algorithms ensure that there are sufficient options available to manage the data traffic efficiently. Standard G.8032 ERPSv2 (Ethernet Ring Protection Switching) provides 50ms protected packet rings for greater resiliency. Multiple ringlets and multiple ring topologies are supported.

**Ethernet OAM:** allows real-time monitoring of end-to-end circuits, connections or trunks, enabling quick detection and isolation of faults to a particular subnet, trunk, link or node. The TJ1400 supports BFD based Fault OAM and ping/traceroute at tunnel/pseudowire level. It also supports MPLS-TP based performance OAM for PW services. For .1q/,1ad based MEF services, Y.1731/802.1ag based CFM OAM (Port level down MEP) and Y.1731 PM counters are supported.

**Mobile Front-haul/Back-haul Features:** TJ1400 enables high-capacity backhaul through Packet/OTN/DWDM. It delivers comprehensive front-haul solutions through CPRI over OTN/DWDM, eCPRI over OTN/DWDM, eCPRI over packet. It also provides circuit emulation for legacy 2G/3G backhaul and GPON/NGPON-2 for 4G/5G small cell backhaul.

**Flexible Network Architectures:** TJ1400 can build a flexible architecture best suited for all services. Linear for rapid deployment, Hub and spoke for cost-effective aggregation. Ring and ringlet for high utilization and resiliency. Meshed for low latency and flexible protection. This is achieved with a unique combination of functionality and ability for every optical port to be an UNI or an NNI.

**Multi-Service Support:** High speed enterprise services through CE2.0, IP-VPN and MPLS-TP, Network modernization through circuit emulation, legacy TDM applications on SONET/SDH, broadband wireless access, Gigabit fiber broadband through GPON and NG-PON and next-generation mobile backhaul through PTN, OTN and WDM.



**Swiss Army Knife Platform**

# TJ1400 Ultra-Converged Broadband Access/Edge Platform

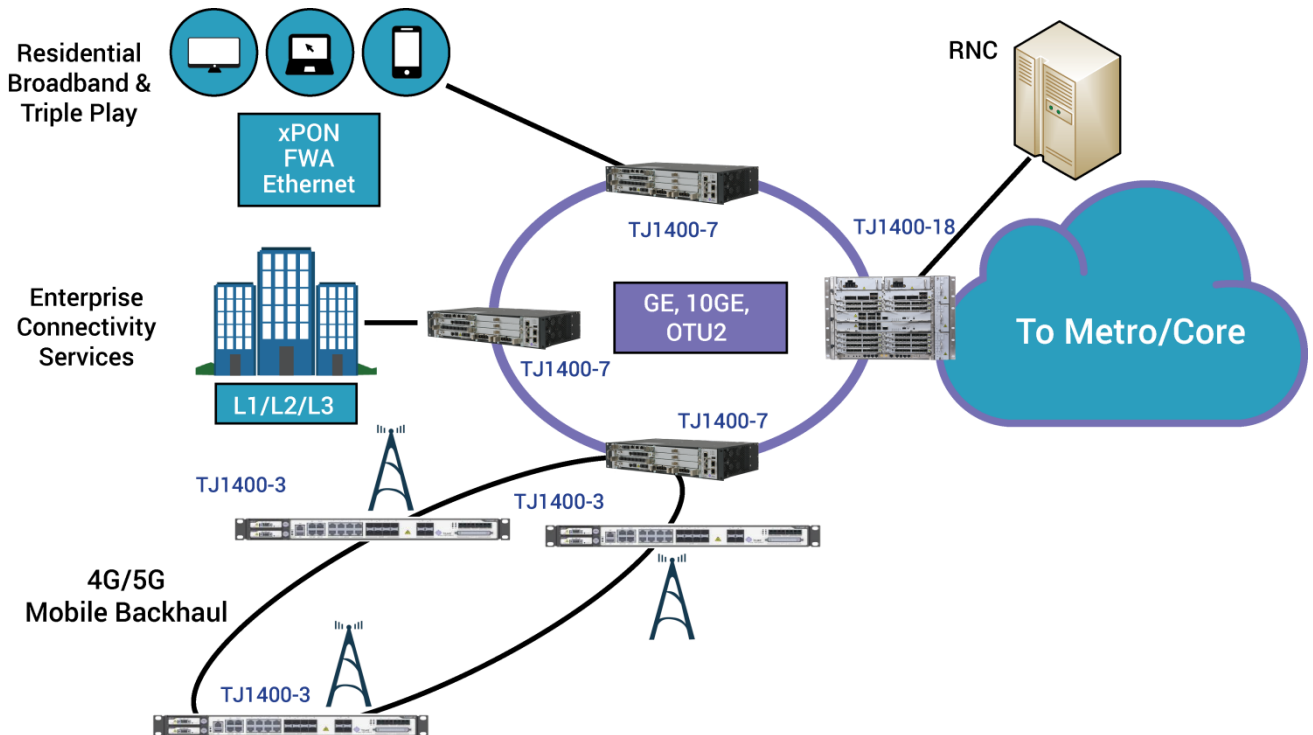

## Unified Service Delivery

### Enterprise Services

- Supports a versatile mix of services ranging from low speed DS1/E1 (2 Mbps), STM-64/OC-192, 10GE/OTU2e (10 Gbps) up to 100GbE
- CE2.0 certified by Metro Ethernet Forum (MEF) for interoperable E-LINE, E-LAN and E-Tree Business Ethernet services
- OTN mapping and switching features both on the Access and Network side to deliver low latency connectivity services
- High-density circuit emulation cards for DACS replacement applications while retaining legacy TDM leased line services

### Mobile Backhaul

- Same platform can be used for 2G/3G/4G and 5G backhaul; simpler converged packet optical equipment with PTN/MPLS-TP, CE2.0 and OTN support instead of using expensive IP/MPLS in the access
- Operators can reuse their existing investments in L2 transport; selective introduction of L3 functionality (e.g., L3 VPN) for 5G mid-haul without requiring expensive network overhaul

- Advanced packet synchronization and circuit emulation features for pure-packet backhaul of 2G/3G voice and TDM services
- Ease of evolution to SDN architecture with centralized control plane and compatible with traditional transport-style operations

### Residential Services

- Fiber broadband (xPON) and Mobile broadband (LTE) services can be delivered using an add-on blade on TJ1400
- Multilevel xPON failure protection at port, fiber and passive splitter levels for offering premium services to SOHOs/SMEs
- Solar powered solutions for ONTs and LTE CPEs in remote areas with power constraints; LTE relay capability for cost-effective coverage expansion in rural areas
- Advanced multicast, IGMP features for efficient delivery of residential triple-play and video-on-demand services
- Seamless upgrade to higher-speed xPON such as NG-PON1/NG-PON2 through software upgrade

## Technical Specifications

### Packet Switching Capacity

Up to 1 Terabit Switch Fabric

### Data Interfaces

- 100GE, 200GE
- 10/100/1000BT, 100LX/FX
- GE (SFP) and 10GE (SFP+), 100GE (CFP2/QSFP28)
- OTU2e, OTU4 with GFEC Support

### Services

- MEF2.0 compliant Carrier Ethernet (E-Line, E-Lan, E-Tree), MPLS
- L2 VPN Services - PW, MS-PW, VPLS & H-VPLS services
- GPON/NG-PON/NG-PON2/XGS-PON
- L3 VPN, VRF/VR over MPLS-TP, BGP IP/MPLS VPN Support

### Line Cards

- Multi-Service Line Card (8xSFP/SFP+ multi-rate/multi-protocol ports)
- 8x10GE Ethernet Line Card (8xSFP+; single slot)
- 2x100GE + 4x10GE (2xCFP2 Port, 4xSFP+)
- 8xGE Ethernet Line Card (8xSFP Ports)
- ST-OLT 8xSFP GPON Card
- PDH CEM Line Cards (63xDS1/E1, 24xDS3/E3)

### Ethernet/MPLS-TP OAM

- MPLS-TP OAM RFC5860
- BFD, ITU Y.1731/802.1ag OAMP
- LSP/PW Ping and Traceroute (RFC6426)
- ERPS (G.8032), 1:1 Linear Protection
- On demand LM/DM at Tunnel/PW level
- On demand LM/DM at VLAN level
- Port Mirroring and Loopback
- Link integrity (LLCF/LLR)
- SNMPv3

### FTTx Features

- NG-PON1/NG-PON2 ready Hardware
- Open ERPS for Enterprise-grade services
- 8/16-port GPON OLT with 1:128 split
- 8xGbE dense ONTs with PoE/RPoE support; Industrial ONTs for IoT
- ITU-T G.984 compliant OMCI

### Circuit Emulation Services

SONET/SDH CEM-CEP: OC-3/12/48 and STM1/4/16, PDH/Electrical CEM: T1/E1 and DS3/E3/EC-1

### WTTx Features

- TD-LTE Release-10
- Configurable bandwidths: 5/10/20 MHz
- 2X2 and 4X4 MIMO
- Up to 30 carriers in one half-depth, 2U rack with eCIC
- Up to 20+20 MHz Carrier Aggregation per radio
- Bands 38, 40, 41, 42, 43
- Up to 30 carriers in one half-depth, 2U rack with eCIC

### Power Supply (optional redundancy)

- 40V to -60V DC
- 2500 Watts maximum per unit

### Environmental

- Extended operating temperature: 65°C
- Humidity: 10 to 90%, non-condensing
- CE, ROHS Compliant
- ETSI/EN 300386
- EN 55022
- FCC Part 15 Class A

### Dimensions (W\*H\*D in mm)

- 2 RU: 445 x 88 x 235
- 5 RU: 445 x 222 x 235
- 7 RU: 482 x 309.75 x 268
- ETSI and 23" rack mount options



Software-Enabled Transformation

Plot No. 25, J.P. Software Park,  
Electronic City Phase-1  
Hosur Road, Bengaluru,  
Karnataka 560100, India  
www.tejasnetworks.com  
+91 8041794600

USA  
KENYA  
SOUTH AFRICA  
NIGERIA  
ALGERIA

UAE  
MALAYSIA  
SINGAPORE  
MEXICO  
BANGLADESH